

BILL OF MATERIALS						
ITEM NO.	Defa ult/Q TY	ITEM	DESCRIPTION	LENGTH	WIDTH	
1	1	LS80770	CBR4SC-RAIL WITH LABEL HOLE ASSM MS			
2	2	LS80765	CBR4SC-WHEEL SUPPORT ASSM HIGH			
3	1	LS80771	CBR4SC-RAIL WITHOUT LABEL HOLE ASSM MS			
4	2	LS80764	CBR4SC-WHEEL SUPPORT ASSM LOW			
5	6	LS28044	DYNABOLT 12mm (M10) x 60mm ZP (DP12060) NOMINAL HOLE DEPTH -50mm	-	-	
6	12	LS28200	SCREW SOCKET C/S M12 x 20 SS304	-	-	
7	2	LS80763	30*8mm PLATE MS CBR4SC-MOUNTING RAIL			

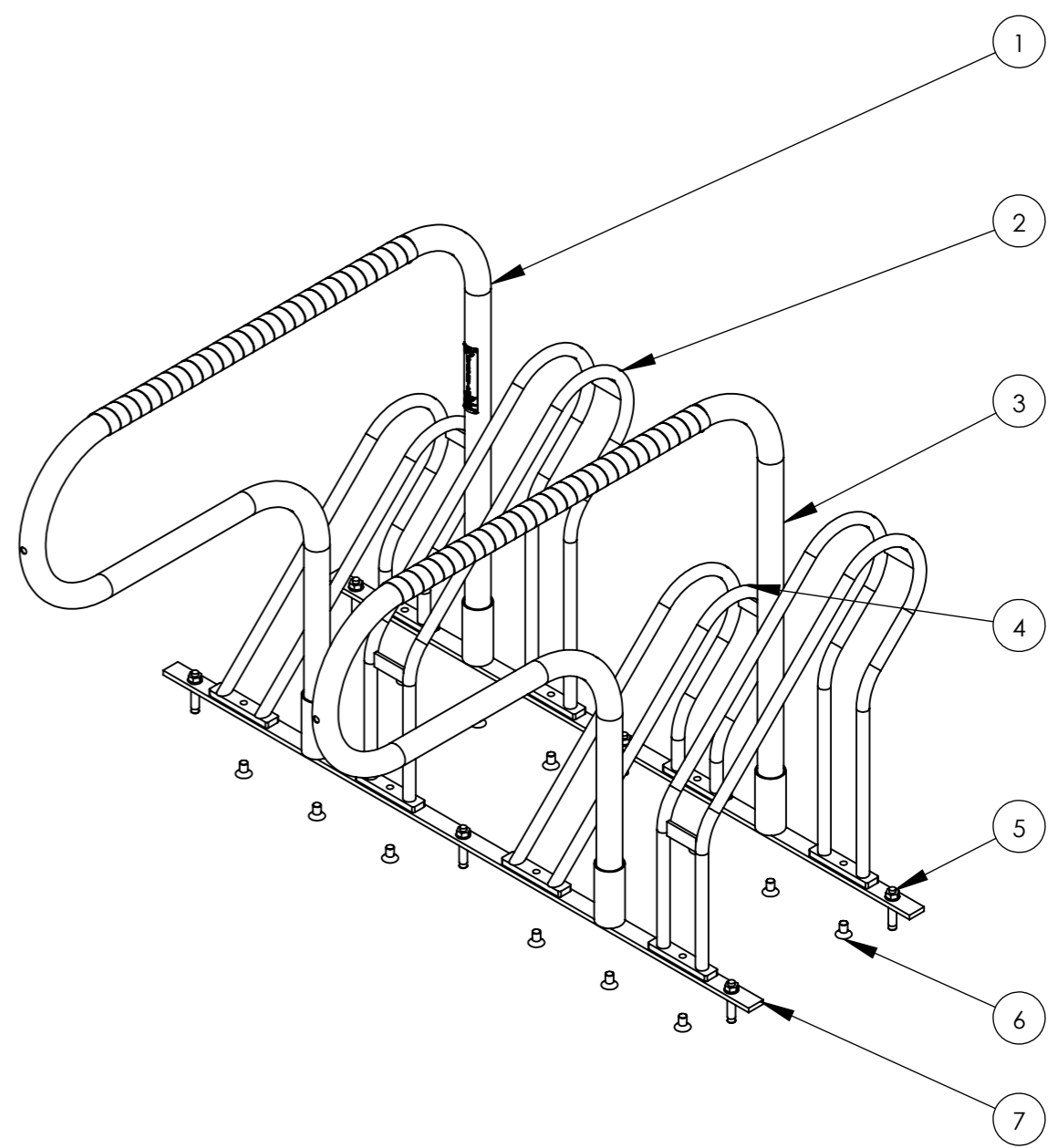

MATERIAL DESCRIPTION: VARIOUS				WEIGHT: kg	
FINISH: VARIOUS		SW FILE: LS80760-CBR4SC-FULLY ASSM			
SCALE: 1:10 AT A3		ANGULAR TOLERANCES			
LINEAL TOLERANCES		THIRD ANGLE PROJECTION			
1.0 to 250 ± 0.2	250 to 500 ± 0.5	500 to 1000 ± 1.0	1000 to 5000 ± 2.5	± 0.5°	



HEAD OFFICE: 18 Reliance Drive, Tuggerah NSW 2258
 Phone +61 2 4353 3377 - Fax +61 2 4353 2255 - Email lvsales@l-v.com.au
 © COPYRIGHT 2015 - ALL INTELLECTUAL PROPERTY RIGHTS RESERVED

ISSUED FOR: MANUFACTURE		DRAWN BY: LIBO	
JOB No.:	CLIENT/SITE:	APPROVED BY: -	
MODEL DESCRIPTION: CBR4SC FULLY ASSM			
ITEM: LS80760	REV: D3 INDEX: -	DRAWING DATE: 2016/6/15	SHEET: 1 OF 1